

MB432 PCB Terminal Block, Modular

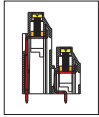

MB432-508MA

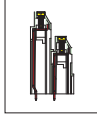

MB432-508MB

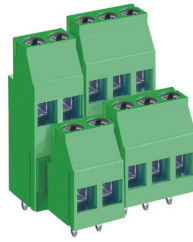

DIMENSIONS/POSITIONS

	MB432-508MA	MB432-508MB
Pitch	5.08mm	5.08mm
Poles	4 ~ 6Poles	4 ~ 6Poles
Dimension A	5.08mm	5.08mm
Length	A=5.08xP/2 + 2.54mm(P≥4)	A=5.08xP/2 + 2.54mm(P≥4)
Housing Material	PA 66	PA 66
Cage Clamp	Brass, Ni Plated	Brass, Ni Plated
Contact	Brass, Tin Plated	Brass, Tin Plated
Screw Thread	M2.6, Steel, Zinc Plated	M2.6, Steel, Zinc Plated
Wire Size	10 ~ 24AWG	10~ 24AWG
PCB Hole Diameter	1.5mm	1.5mm
Tightening Torque, Max.	6.0 Lb-in	6.0 Lb-in
Operating Temperature	-40°C to +105°C	-40°C to +105°C

TECHNICAL DATA

Connection in acc. with standard EN-VDE		
Nominal Current I _N	25A	25A
Nominal Cross Section	4.0mm ²	4.0mm ²
Maximum load current	25A	25A
Insulating Material	PA	PA
Inflammability class acc. to UL94	V0	V0
Nominal voltage, UL/CUL	300V	300V
Nominal current, UL/CUL	25A	25A

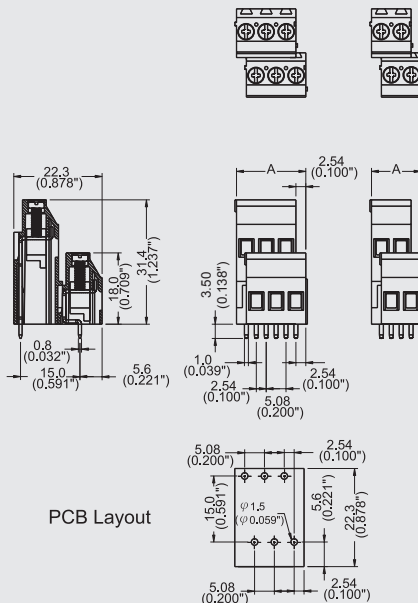

PCB Layout

Note:
Screw Plating: Changes are available upon request

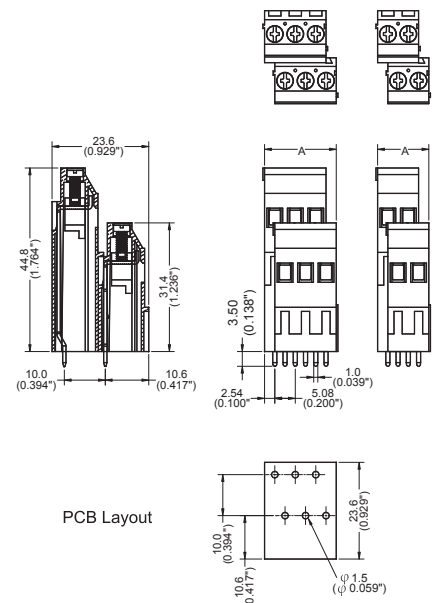

PCB Layout