

# MC100# Connector, Pluggable Terminal Blocks

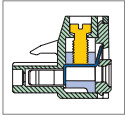

## DIMENSIONS/POSITIONS

	MC100#500	MC100#508
Pitch	5.00mm	5.08mm
Poles	2 ~ 24Poles	2 ~ 24Poles
Dimension A	5.00mm	5.08mm
Length	A= 5.00xP(P≥2)	A= 5.08xP(P≥2)
Housing Material	PA 66	PA 66
Cage Clamp	Steel, Ni Plated	Steel, Ni Plated
Contact	Phosphor Bronze, Tin Plated	Phosphor Bronze, Tin Plated
Screw Thread	M2.6, Steel, Zinc Plated	M2.6, Steel, Zinc Plated
Wire Size	12 ~ 24AWG	12 ~ 24AWG
Tightening Torque, Max.	7.0 Lb-in	7.0 Lb-in
Operating Temperature	-40°C to +105°C	-40°C to +105°C

## TECHNICAL DATA

Connection in acc. with standard EN-VDE		
Nominal Current I <sub>N</sub>	16A	16A
Nominal Cross Section	4.0mm <sup>2</sup>	4.0mm <sup>2</sup>
Maximum load current	16A	16A
Insulating Material	PA	PA
Inflammability class acc. to UL94	V0	V0
Nominal voltage, UL/CUL	300V	300V
Nominal current, UL/CUL	16A	16A

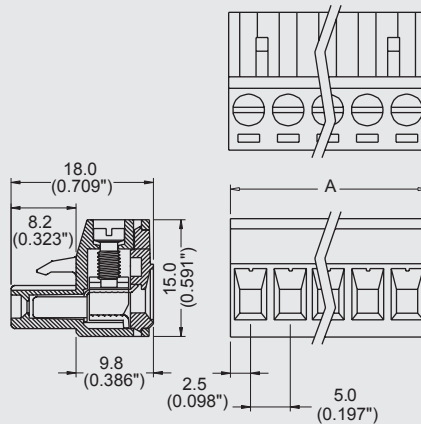

Note:  
 Screw Plating: Changes are available upon request  
 Cage Clamp: MC 100- : Brass

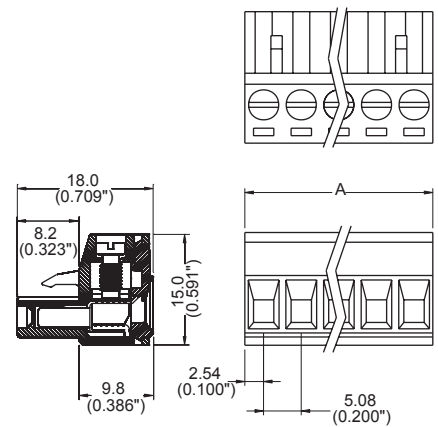

Note:  
 Screw Plating: Changes are available upon request  
 Cage Clamp: MC 100- : Brass